

# ELECTRIC PLATFORM TRUCK

# EPTi / EPTPi Series



**Model : EPTi Series**  
**Capacity : 300kg / 500kg**

- AC technology
- Perfect for driving in stores & warehouses
- Ideal for transporting non-standard non-palletized loads between locations
- High ground clearance and solid rubber tyres
- Wide ladder steps for order picking in high shelves

**OPTIONS**

- Battery discharge indicator with hour meter
- Double platform for enhanced productivity
- Stepless electronic speed controller
- Cage enclosure

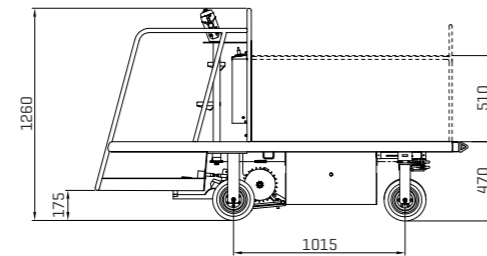
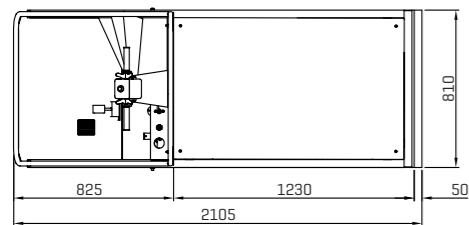

**Model : EPT 5Pi**  
**Capacity : 500kg**

EPT 5Pi is an order picker version. The platform has a scissor lift mounted enabling a 2100mm lift from the ground. This enables easy picking of light loads. Ideal for small stores and spare parts warehouses.

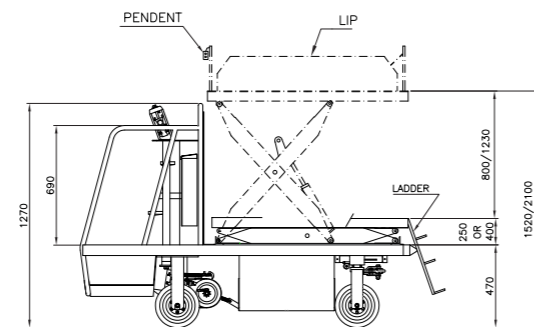

All dimensions in mm.  
 Materials and specifications are subject to change without notice

**MAINI  
 MATERIALS  
 MOVEMENT**



Value delivered. Always

ELECTRIC PALLET TRUCK

ELECTRIC PLATFORM TRUCK

**SIMPLIFYING  
 MATERIAL HANDLING  
 & WAREHOUSING**



# FLOOR TRANSPORTATION

To know more about Maini's comprehensive solutions to simplify material handling and warehousing, write to me at [mtrlsmov@maini.com](mailto:mtrlsmov@maini.com)

**MAINI BRANCH OFFICES**

- NORTH REGION : Gurgaon
- SOUTH REGION : Bengaluru, Chennai
- WEST REGION : Mumbai, Pune, Ahmedabad, Vadodara

**PAN INDIA CHANNEL PARTNERS**

- Ahmedabad • Aurangabad • Bengaluru • Chandigarh • Chennai • Cochin
- Coimbatore • Faridabad • Ghaziabad • Goa • Gurgaon • Hosur • Hyderabad
- Indore • Jamshedpur • Kanpur • Kolhapur • Kolkata • Madurai • Mumbai
- Nagpur • Nashik • Noida • Pune • Satara • Vapi • Visakhapatnam



For enquiries please contact:  
**MAINI MATERIALS MOVEMENT PVT. LTD.**  
 Sy. 32, Chandapura, Hosur Road, Bengaluru - 560 099, INDIA.  
 Phone: +91 80 4352 6555 Fax: +91 80 4352 6580

JANUARY 2016  
 Features and specifications subject to change.

Visit us at  
[www.mainimaterials.com](http://www.mainimaterials.com)

# FLOOR TRANSPORTATION



Maini's range of Floor Transportation equipment includes the quintessential Electric Pallet Trucks and Electric Platform trucks, designed to enhance productivity, ensure safety and optimize returns. Streamlined design and small turning radius makes it ideal for operating in narrow passageways. With Maini in your warehouse, you can be rest assured that you can transport your loads just the way you want.

## FEATURES



**TOTAL OPERATOR COMFORT**  
Ergonomically designed handle for enhanced steering comfort



**EASY MAINTENANCE**  
Modular drive unit, hydraulics and electronics ensure easy access for service



**RIDER COMFORT**  
Vibration-damped stand-on platform [Available in SP 20i & SP 25i only]



**QUICK BATTERY CHANGE**  
Standard battery rollers for quick and effortless replacement



**EASE OF OPERATION**  
Ergonomic construction for steering comfort and easy serviceability



**GUARANTEED STABILITY**  
Articulating type steering axle ensures constant road grip



**POSITIVE BRAKING SYSTEM**  
Parking brake for added safety

## ENGINEERING EXCELLENCE

- Easy Operation** : Control and operation simplicity
- Enhanced Safety** : Switch which simultaneously cuts-off power supply to motor and actuates parking brake
- Speed Control** : In SPi Series, the microprocessor based motor controller gives precise and step - less throttle control
- Quick Battery Change** : The standard battery rollers facilitate quick and effortless replacements
- High Reach** : In EPTi Series the ladder steps enable picking of loads from higher shelves
- Manoeuvrability** : EPTi is designed to work in confined spaces with smaller turning radius

### TECHNICAL SPECIFICATIONS : SPi SERIES & EPTi SERIES

Features	Unit	ELECTRIC PALLET TRUCK				ELECTRIC PLATFORM TRUCK	
		SP 20i	SP 25i	SP 36*	SP 50*	EPT 5i	EPT 5P
Capacity	kg	2000	2500	3600	5000	500	300
Pump Motor	kW	2.0	2.0	2.0	2.0	NA	NA
Drive Motor	kW	1	1.5	1.5	2.5	1.7	1.7
Max. Travel Speed - Unladen / Laden	km/hr	4 / 4	7.5 / 5.5	5.5 / 4.5	4.5 / 3.5	14 / 10	14 / 10
Gradeability - Unladen / Laden	%	10 / 5	10 / 5	10 / 5	10 / 3	20 / 15	20 / 15
Max. travel distance on gradient	m	20	20	15	15	NA	NA
Lifting speed - Unladen / Laden	m/s	1.5 / 2	1.9 / 2	2.5 / 4.3	2.5 / 4	NA / NA	NA / NA
Lowering speed - Unladen / Laden	m/s	15 / 5.5	15 / 5.5	22 / 5.8	22 / 3	NA / NA	NA / NA
Battery capacity	V, Ah	24, 160	24, 244	24, 345	24, 345	12, 210	12, 210
Net weight - Without battery / With battery	kg	465 / 635	450 / 735	580 / 865	690 / 980	200 / 380	420 / 600
Wheels [Solid Rubber]	mm					250x100	250x100

\* SP 36 & SP 50 variants are available in DC versions

## ELECTRIC PALLET TRUCK | SPi Series



SP 20i / SP 25i / SP 36 / SP 50

Model : **SPi Series**  
Capacity : **2000kg - 5000kg**

- Horizontal transport of goods
- Ideal for high intensity movement
- Compact design
- Can be used with a dock leveler for container loading

Model	L2	L1	X	Y
SP 20i	770	1150	90	205
SP 25i	790	1150	90	205
SP 36*	790	1220	90	225
SP 50*	790	1220	110	245

### DIMENSIONAL SPECIFICATION : SPi Series

