

HW - 4(H) WIRE ROPE HOISTS

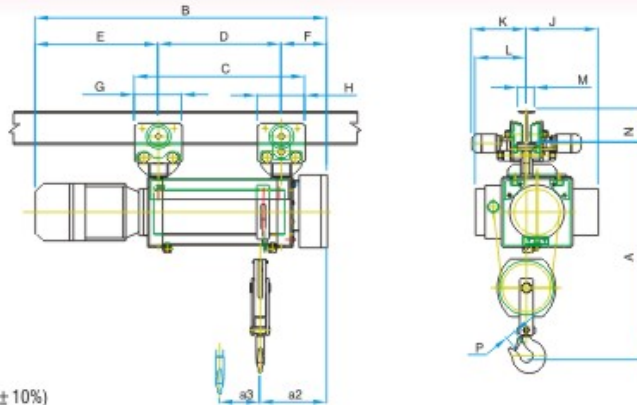
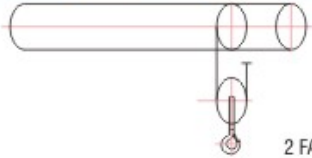
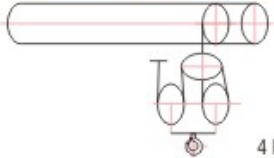

SPECIFICATION & DIMENSIONS (APPROX.) (± 10%)

TYPE		HW - 4 (H)														
		H1	H2	H3	H4	H5	H6	H7	H1	H2	H3	H4	H5	H6	H7	
DRUM LENGTH.	MM	695	827	976	1201	1426	1651	1876	695	827	976	1201	1426	1651	1876	
SWL CLASS - II	TONNES	10							20							
SWL CLASS - IV	TONNES	8							16							
LIFT	M	10.5	14	18	24	30	36	42	5.25	7	9	12	15	18	21	
NO. OF FALLS		 2 FALLS							 4 FALLS							
WIRE ROPE DIA.	MM	18							18							
HOISTING SPEED	M/MIN.	6.7							3.3							
HOISTING MOTOR KW.	KW	15							15							
TRAVELLING SPEED	M/MIN.	17							17							
TRAVELLING MOTOR KW.	KW	0.55 KW (2 NOS.)							0.75 KW (2 NOS.)							
DIMN. A (HEAD ROOM)	MM	1860							1840							
DIMN. ((B)) Note-6	MM	1911	2043	2192	2417	2642	2867	3092	1911	2043	2192	2417	2642	2867	3092	
DIMN. C	MM	991	1123	1272	1497	1722	1947	2172	1121	1253	1402	1627	1852	2077	2302	
DIMN. D	MM	635	767	916	1141	1366	1591	1816	635	767	916	1141	1366	1591	1816	
DIMN. E	MM	Note-5 (785) ((920))							(785) ((920))							
DIMN. F	MM	356							356							
DIMN. G	MM	356							486							
DIMN. H	MM	356							486							
DIMN. J	MM	539							500							
DIMN. K	MM	410 - 460							410 - 480							
DIMN. L	MM	381							420							
DIMN. M	MM	125 - 210							150 - 210							
DIMN. N (MIN.)	MM	250							450							
DIMN. P	MM	78							95							
DIMN. a2	MM	548							652							
DIMN. a3	MM	99	155	220	317	415	512	609	40	78	121	186	250	315	380	
APPROX. WEIGHT	HOIST	KG	480	504	510	550	596	642	688	530	550	570	590	696	742	788
	TROLLEY	KG	140	140	140	140	140	140	140	180	180	180	180	180	180	180
	TOTAL	KG	620	644	650	690	736	782	828	710	730	750	770	876	922	968

NOTES:

- 1) 1:3 CREEP SPEED CAN BE GIVEN AT EXTRA COST & DIMENSION 'E' WILL INCREASE BY 165 MM.
- 2) TROLLEY BRAKE CAN BE SUPPLIED AT EXTRA COST AND DIMENSION 'K' WILL INCREASE BY 125 MM.
- 3) 13, 26 MPM TROLLEYS ALSO CAN BE SUPPLIED (SINGLE REDUCTION GEAR BOX) TROLLEY KW RATING WILL CHANGE.
- 4) 2, 2.8, 4, 8, 9 MPM TROLLEYS ALSO CAN BE SUPPLIED (DOUBLE REDUCTION GEAR BOX) AT EXTRA COST AND 'K' DIMENSION WILL INCREASE BY 46 MM. TROLLEY KW RATING WILL CHANGE.
- 5) SPECIFICATIONS IN (()) ARE FOR IMPORTED (COEL) MOTOR WITH AC BRAKES.
- 6) SPECIFICATIONS IN () ARE FOR LOCAL (BBL) MOTOR WITH AC BRAKES.