

HW - 2 WIRE ROPE HOISTS

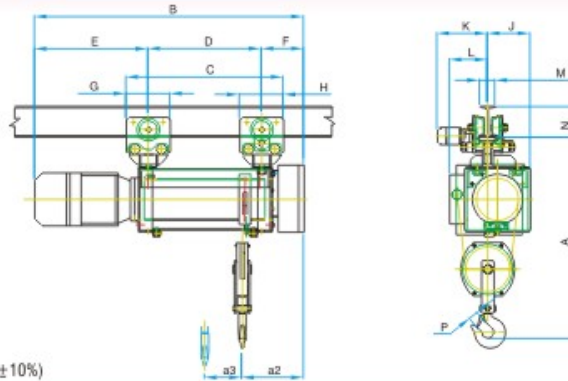
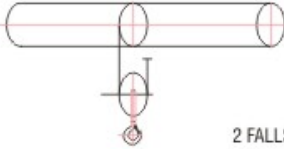
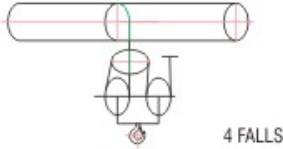

SPECIFICATION & DIMENSIONS (APPROX.) (±10%)

TYPE		HW - 2														
		H1	H2	H3	H4	H5	H6	H7	H1	H2	H3	H4	H5	H6	H7	
DRUM LENGTH.	MM	583	699	832	1032	1232	1432	1631	583	699	832	1032	1232	1432	1631	
SWL CLASS - II	TONNES	3							6							
SWL CLASS - IV	TONNES	2.5							5							
LIFT	M	10.5	14	18	24	30	36	42	5.25	7	9	12	15	18	21	
NO. OF FALLS		 2 FALLS							 4 FALLS							
WIRE ROPE DIA.	MM	10							10							
HOISTING SPEED	M/MIN.	8.2							4.1							
HOISTING MOTOR KW.	KW	5.5							5.5							
TRAVELLING SPEED	M/MIN.	17							17							
TRAVELLING MOTOR KW.	KW	0.37 KW							0.55 KW							
DIMN. A (HEAD ROOM)	MM	1280							1240							
DIMN. B	MM	1461	1577	1710	1910	2110	2310	2509	1461	1577	1710	1910	2110	2310	2509	
DIMN. C	MM	873	989	1122	1322	1522	1722	1921	873	989	1122	1322	1522	1722	1921	
DIMN. D	MM	553	669	802	1002	1202	1402	1601	553	669	802	1002	1202	1402	1601	
DIMN. E	MM	Note-6			(675) ((583))				(675)			((583))				
DIMN. F	MM	233							233							
DIMN. G	MM	320							320							
DIMN. H	MM	320							320							
DIMN. J	MM	210							243							
DIMN. K	MM	400 - 425							410 - 460							
DIMN. L	MM	321							205							
DIMN. M	MM	90 - 180							125 - 210							
DIMN. N (MIN.)	MM	Note-5			175				250							
DIMN. P	MM	42							52							
DIMN. a2	MM	370							406							
DIMN. a3	MM	158	216	282	382	482	582	682	93	132	176	243	310	376	442	
APPROX. WEIGHT	HOIST	KG	220	234	249	272	303	318	341	242	256	271	294	317	340	363
	TROLLEY	KG	120	120	120	120	120	120	120	120	120	120	120	120	120	120
	TOTAL	KG	340	354	369	392	423	438	461	362	376	391	414	437	460	483

NOTES:

- 1:3 CREEP SPEED CAN BE GIVEN AT EXTRA COST & DIMENSION 'E' WILL INCREASE BY 165 MM.
- TROLLEY BRAKE CAN BE SUPPLIED AT EXTRA COST AND DIMENSION 'K' WILL INCREASE BY 125 MM.
- 13, 26 MPM TROLLEYS ALSO CAN BE SUPPLIED (SINGLE REDUCTION GEAR BOX) TROLLEY KW RATING WILL CHANGE.
- 2, 2.8, 4, 8, 9 MPM TROLLEYS ALSO CAN BE SUPPLIED (DOUBLE REDUCTION GEAR BOX) AT EXTRA COST AND 'K' DIMENSION WILL INCREASE BY 46 MM. TROLLEY KW RATING WILL CHANGE.
- CHECK 'I' BEAM MOUNTING ARRANGEMENTS, TROLLEY PLATE WILL PROJECT 10 MM ABOVE 'I' BEAM.
- SPECIFICATIONS IN (()) ARE FOR IMPORTED (COEL) MOTOR WITH AC BRAKES.
- SPECIFICATIONS IN () ARE FOR LOCAL (BBL) MOTOR WITH AC BRAKES.

